

TRL Series for fully automatic banding

The Bandall TRL Series is a fully automatic banding and bundling installation where the products are transported into and out of the banding arch in a straight line.

Straight line convey-band-convey

The infeed and outfeed conveyors are parallel to each other and lead the products in one way through the banding arch. A double pusher system ensures accurate positioning of the products in the banding arch. The choice of a TRL model depends on the specifications particular to your processing situation.

This model for banding labels shows the infeed and outfeed conveyors in a straight line

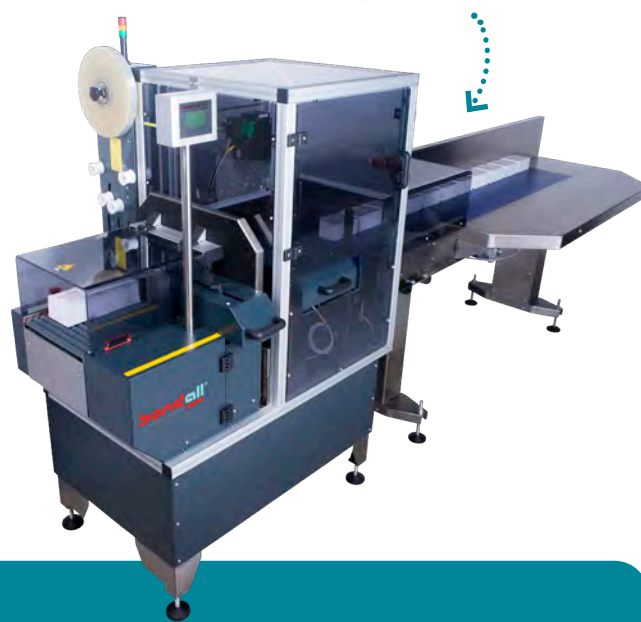

The TRL model is easily integrated with various conveying systems



Modular construction and optional extras

Some of the many benefits

- › **Fast bundling and banding process** (18 to 25 bands per minute)
- › **Easily integrated** into existing production lines
- › **Communication** with other systems in line
- › **Guaranteed Bandall quality**
- › **100% Dutch design**, engineering and manufacture
- › **User friendly** and extremely reliable
- › All models include the **band transport system** that is unique to Bandall equipment



Full integration into fully automatic lines

A Stainless Steel conveyor is available in various lengths



The Bandall TRL Series consists of the following

- › Bandall banding unit
- › Pneumatic side pusher
- › Almost empty roll sensor
- › External Reel Holder
- › Band-in-arch-sensor
- › Signal exchange and signal lamp
- › Free-rolling roller outfeed conveyor
- › Infeed pusher with Servo motor, enabling easy programming
- › Polycarbonate protection cover
- › Adjustable feet are the standard option
- › Stopper between the external conveyor and the infeed conveyor to separate products where required
- › IP 65 control cabinet

Easily equipped with printers for variable product information, bar codes, serial numbers, etc.



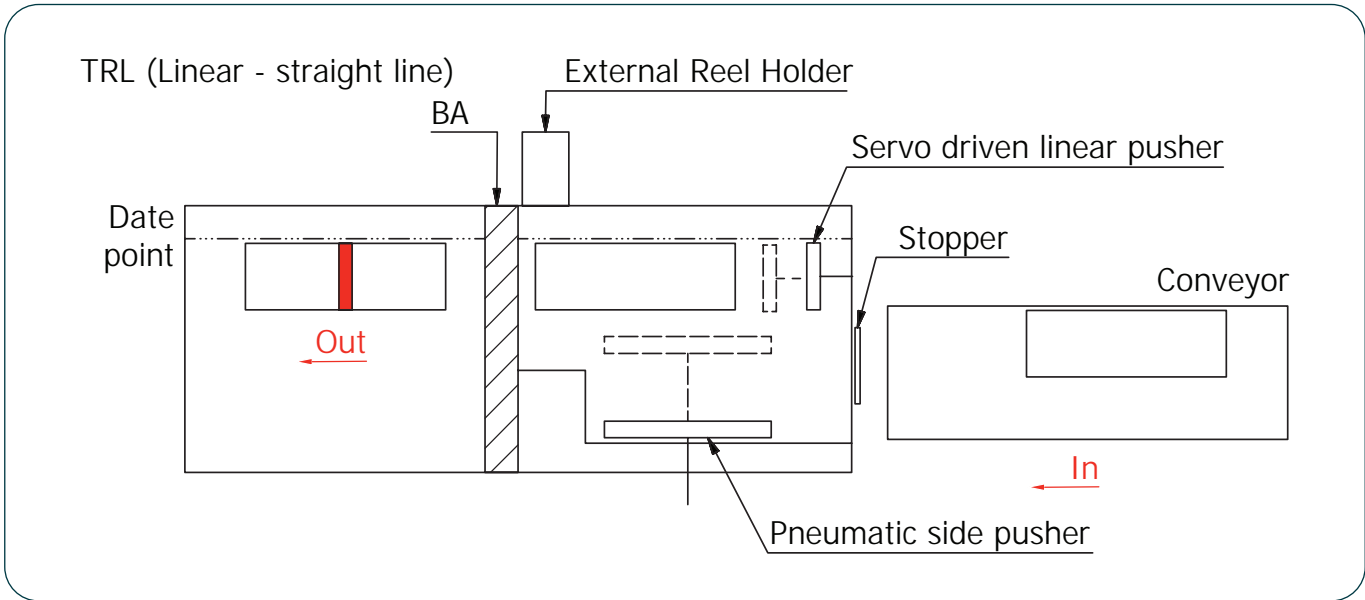

Options

- › Stainless Steel (including SS bearings)
- › Positioning system
- › Various infeed and outfeed conveyors, for example a 600 mm driven roller conveyor, or food grade conveyors
- › Easily equipped with printers to enable printing of variable product information, bar codes, serial numbers, while banding
- › Press
- › Mobile frame (including adjustable feet)

Various pushers enable perfect positioning

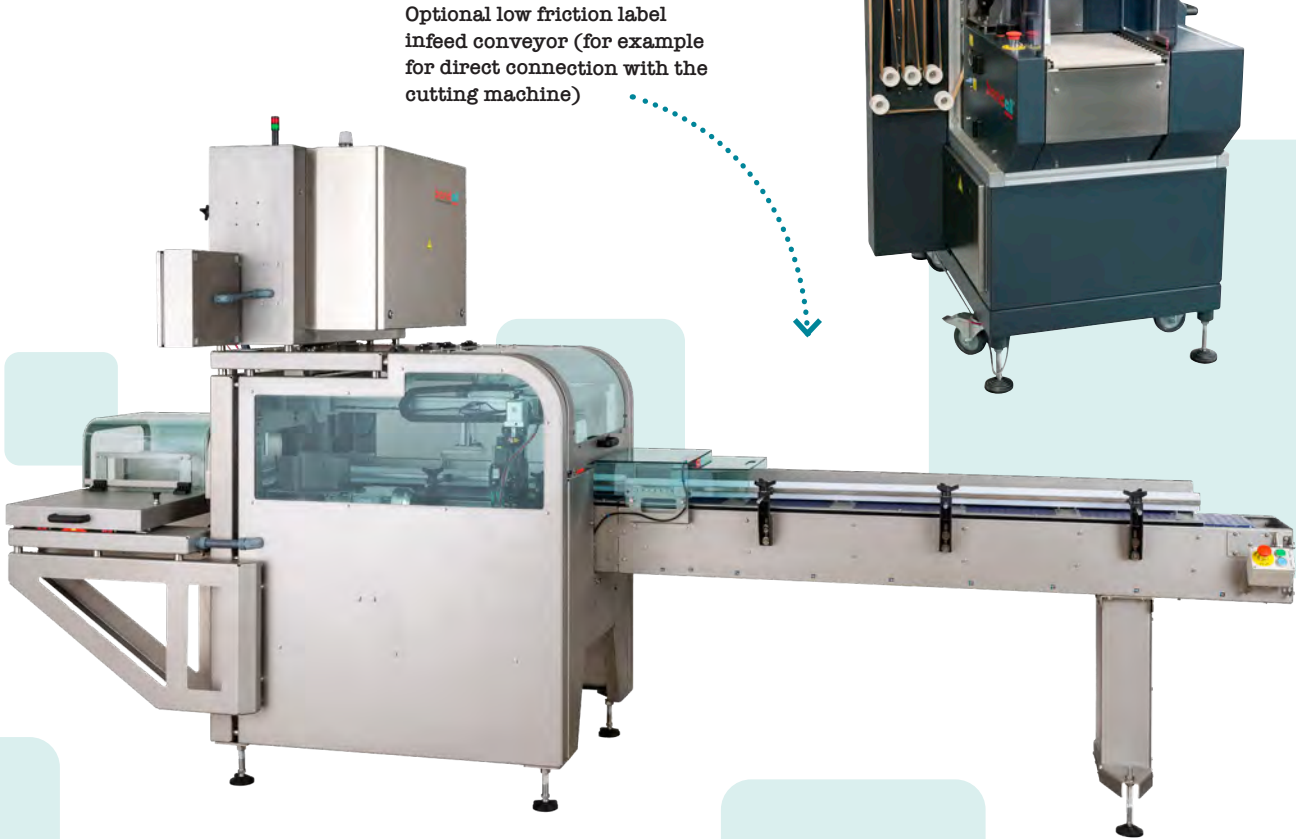

Optional low friction label infeed conveyor (for example for direct connection with the cutting machine)

Suitable for use in many industries including

- › Food
- › Graphics
- › Health & Beauty
- › Logistics and Transport
- › Pharmaceutical

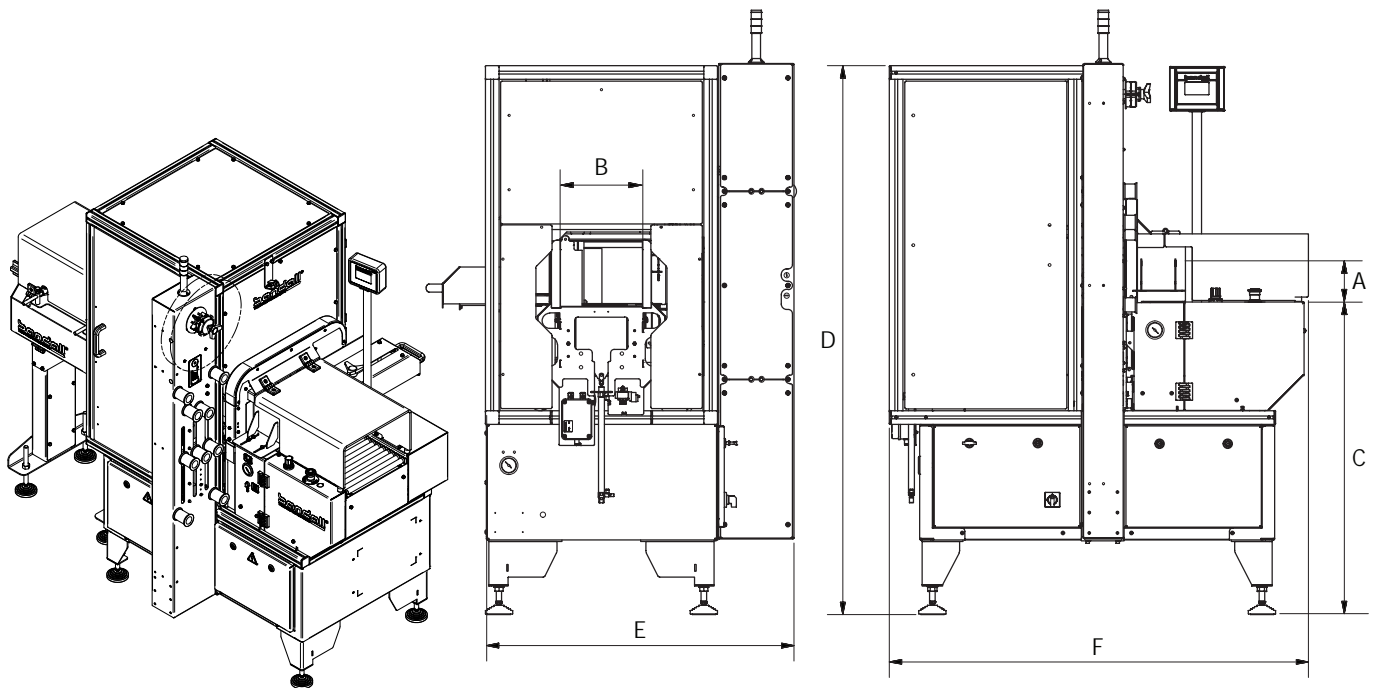

MACHINE TYPE	A Maximum product height	B Maximum product width	C* Standard working height	D* Total standard height	E Total standard width	F** Total length	*** Bundles/min.
TRL 240	150	230	900	1607	900	1227	25
TRL 400	200	385	900	1607	1100	1551	25

All measurements are in millimeters. Upon request we will be pleased to offer you our suggestions with technical specifications tailored to your requirements. Available in a wide range of arch sizes. The standard band channel widths process banding materials of 28, 40, 48, 60, 75 and 100 mm.

* The standard height can be adjustable by -18 and +40 mm. Different heights are optional.

** Dependent on band channel width. *** Dependent upon the product.

EE/OE

